

COMPLIANCE WITH THE USB STANDARD

USB (AXJ1) CONNECTORS

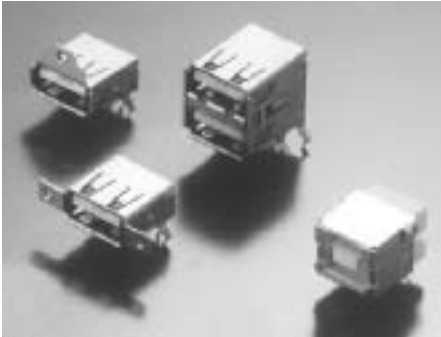

USB: Universal Serial Bus serial interface for connecting a telephone, board and other peripheral units to a personal computer.

FEATURES

- 1. Compliant with the USB standard: permits connection/disconnection while the power is on.
- 2. Resistant structure for mating stress
- 3. Low insertion force/Insertion and removal life 1,500 times

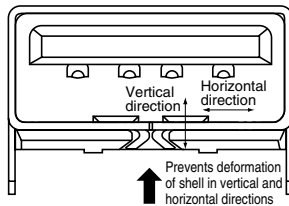

A construction which protects the connector from cable stretching and other external forces is achieved by interfitting the metal shell cover into the molding.

4. A wide variety is available

- Series A: used for PCs and USB hubs
- Series B: used for peripheral units of PCs

APPLICATIONS

- Receptacle
- Series A:** Personal Computers and USB hubs.
- Series B:** Peripheral units of PCs; Printers, speakers, modems, scanners, key boards, joy sticks, computer mouse, telephones and USB hubs

PRODUCT TYPES

Series	No. of port	Terminal shape	Holding parts shape	Flange	Part no.	Packing quantity	
						Inner carton	Outer carton
A	1 port (4 contacts)	DIP terminal	Clinching type Applicable board thickness 0.8mm to 1.2mm	Side flange	AXJ111212T	90	900
				Center flange	AXJ111222T	90	900
				Without flange	AXJ111202T	90	900
	2 ports (4 contacts × 2-layer)	SMD terminal	Straight type	Side flange	AXJ111512T	90	900
				Without flange	AXJ111502T	90	900
				Without flange	AXJ112202T	60	600
B	1 port (4 contacts)	DIP terminal	Clinching type Applicable board thickness 1.6mm	Without flange	AXJ112302T	60	600
			Clinching type Applicable board thickness 1.6mm	Without flange	AXJ115301S	30	900

Remark: T: Tray packaging
S: Tube packaging

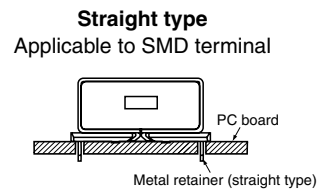
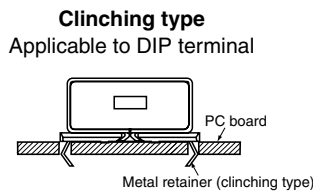

AXJ(1)

SPECIFICATIONS

1. Characteristics

Item	Specifications		Conditions	
Electrical characteristics	Rated current	1.0A		
	Rated voltage	30V DC/AC		
	Contact resistance	1 Port (receptacle)	Max. 30mΩ	EIA-364-23 (Inductive resistance for wire is not included)
		2 Ports (receptacle)	Max. 40mΩ	
	Insulation resistance	Min. 1000MΩ		EIA-364-21 Using 500V DC megger
	Breakdown voltage	Breaking voltage 750V AC for 1min.		EIA-364-20 Detection current: 1mA
Electrostatic capacity	Max. 2pF		EIA-364-30 Measured at 1 kHz between connectors which are not connected.	
Mechanical characteristics	Composite insertion force	Max. 35N {3.57kgf} (initial)		
	Composite removal force	Min. 10N {1.02kgf}		
Environmental characteristics	Ambient temperature	0°C to +40°C (carrying current)		
	Soldering heat resistance	260°C within 10sec.		
		Tip temperature of soldering iron: 300°C within 5sec., 350°C within 3sec.		
Storage condition	-40°C to +60°C		No freezing at low temperatures	
Lifetime characteristics	Mechanical life	1500 times		
Unit weight	1 port type: 2.0 g, 2 parts type: 5.5 g			

2. Material and surface treatment

1) Series A

Part name	Material	Surface treatment
Resin-molding portion	Heat-resistant resin (UL94V-0)	—
Contact	Copper alloy	Contact portion: Au plating over Ni Terminal portion: Au plating over Ni (except for top of the terminal)
Shell	Copper alloy	Sn plating over Cu (except for thick of the terminal)
Center clip	Copper alloy	Sn plating over Cu (except for thick of the terminal)

2) Series B

Part name	Material	Surface treatment
Resin-molding portion	PBT resin (UL94V-0)	—
Contact	Copper alloy	Contact portion: Au plating over Ni Terminal portion: Au plating over Ni (except for top of the terminal)
Shell	Copper alloy	Sn plating over Cu

DIMENSIONS

mm General tolerance: ±0.3

1. Series A 1 port DIP terminal with side flange

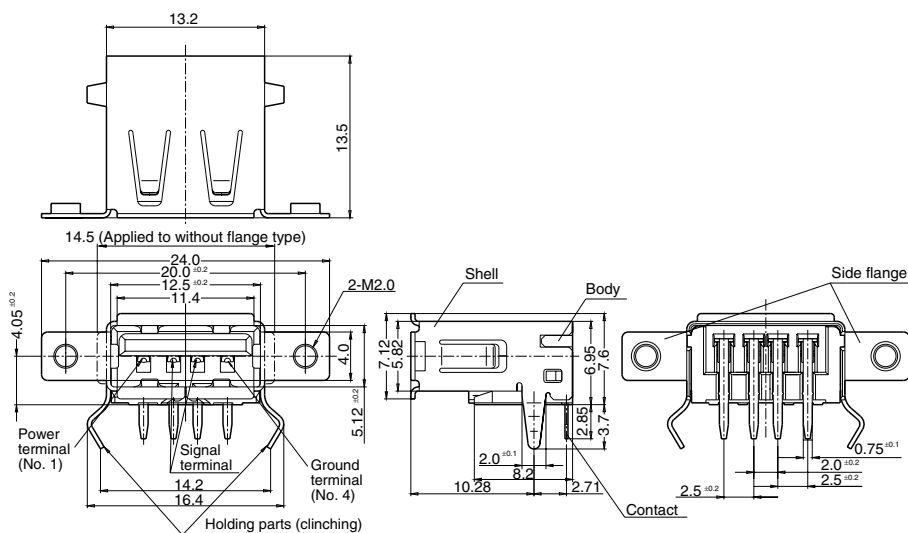

Recommended PC board pattern (TOP VIEW)

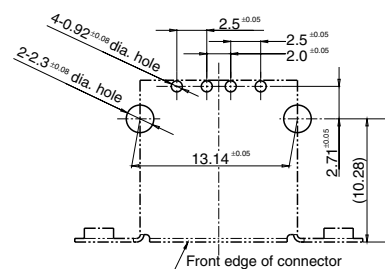

Note) Since product bottom is a metal shell, do not make pattern circuits (to prevent shorting).

Part no.	Flange shape
AXJ111202	Without flange
AXJ111212	With side flange

2. Series A 1 port DIP terminal with center flange

mm General tolerance: ±0.3

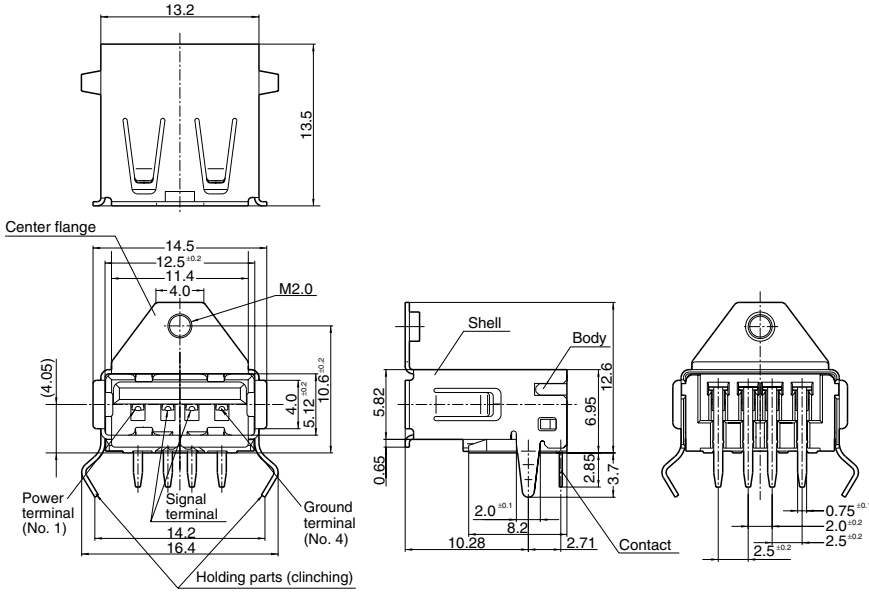

Recommended PC board pattern (TOP VIEW)

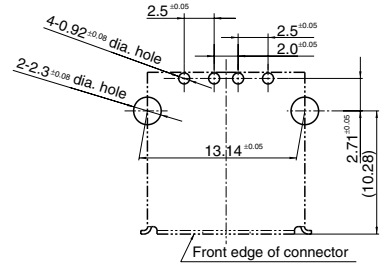

Note) Since product bottom is a metal shell, do not make pattern circuits (to prevent shorting).

3. Series A 1 port SMD terminal with side flange

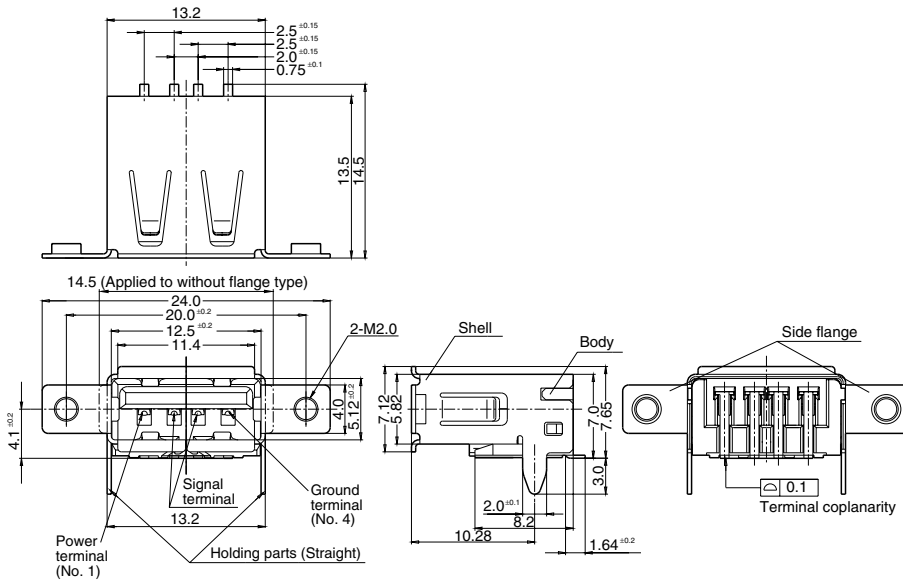

Recommended PC board pattern (TOP VIEW)

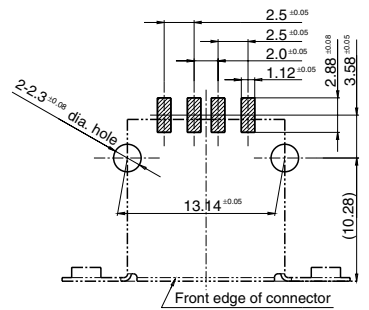

Note) Since product bottom is a metal shell, do not make pattern circuits (to prevent shorting).

Part no.	Flange shape
AXJ111502	Without flange
AXJ111512	With side flange

AXJ(1)

4. Series A 2 ports DIP terminal without flange

mm General tolerance: ± 0.3

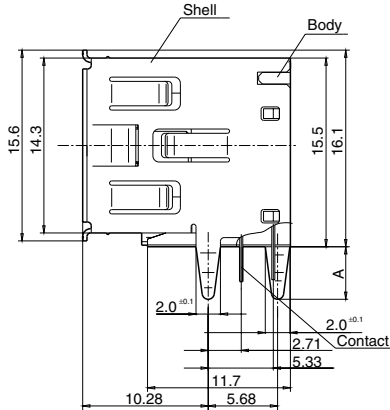
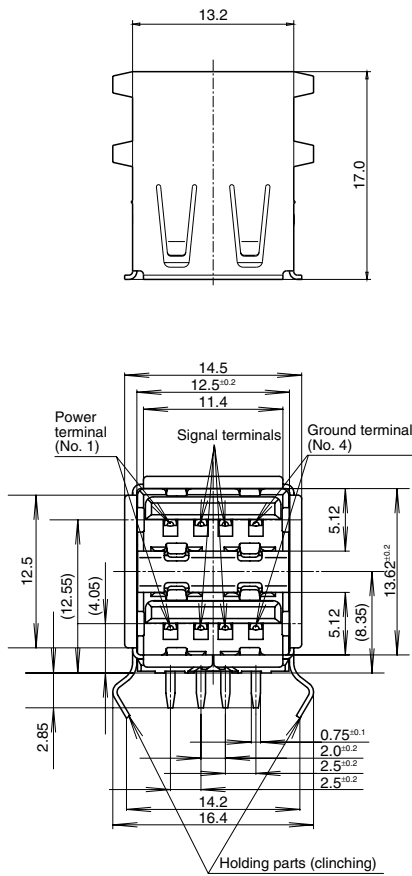

Recommended PC board pattern (TOP VIEW)

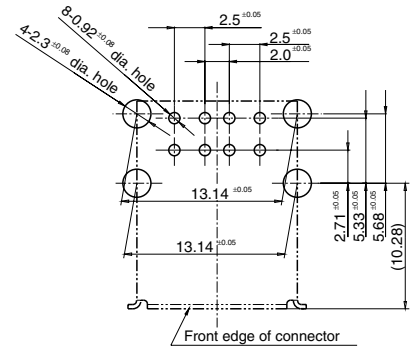

Note) Since product bottom is a metal shell, do not make pattern circuits (to prevent shorting).

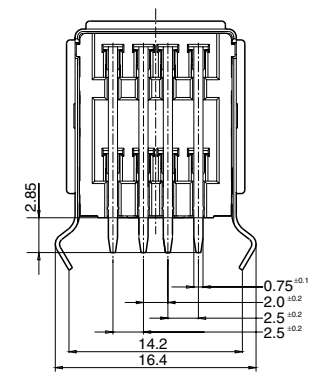

Part no.	A	Applicable PC board thickness
AXJ112202	3.7	0.8mm to 1.2mm
AXJ112302	4.3	1.6mm

5. Series B 1 port DIP terminal without flange

Recommended PC board pattern (TOP VIEW)

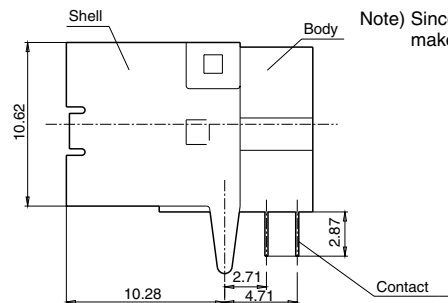
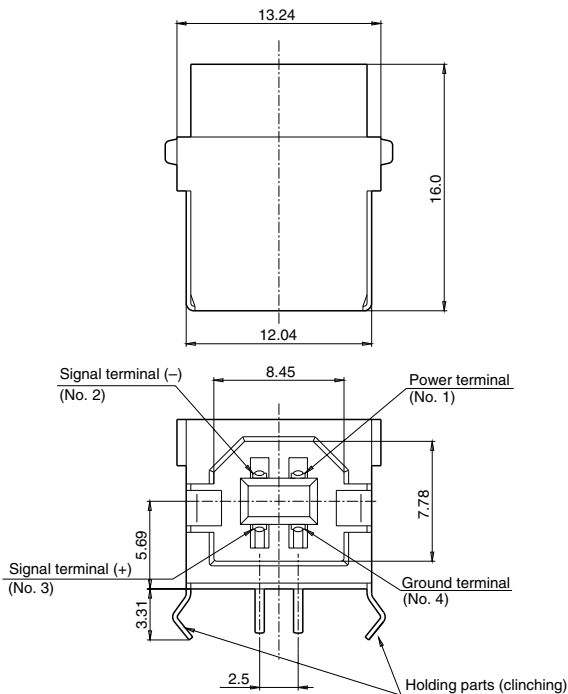

Note) Since product bottom is a metal shell, do not make pattern circuits (to prevent shorting).

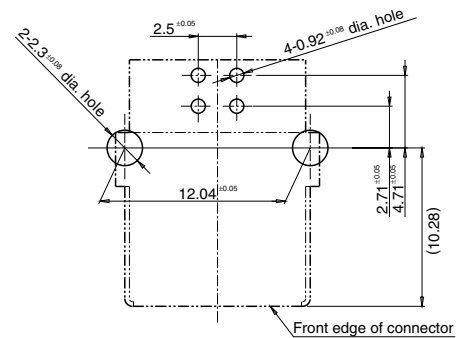

NOTES

1. Use of a cover is recommended when using this device in order to prevent scraps, dust, dirt, etc., from getting inside the receptacle.
2. Since these products come with metal retainers, the foot patterns for two retainers (in the case of 1 port) or for 4 retainers (in the case of 2 ports) must be fabricated. (Refer to the diagram for the recommended PCB processing.) Furthermore, the retainers must be soldered to the PCB to anchor them in place.
3. In the case of automatic soldering, ensure that the solder bath temperature is less than 260°C and that the immersion time does not exceed 10 seconds.
4. Since excessive force on the terminals will cause deformation and the integrity of the soldering will be lost during reflow soldering, avoid dropping or rough handling of the product.
5. This connector has metal shell for preventing EMI, when designing an enclosure the followings should be considered. Guide for plug entrance should be arranged in order to prevent distorted insertions. Provide a cover to reinforce the metal shell portions of the receptacle.
6. Repeated bending of terminals and holding parts can result in terminals breaking.
7. The compatible PCB thickness is either 0.8mm to 1.2mm or 1.6mm for the DIP type of mounting.
In regard to the compatible PCB thickness range from 0.8mm to 1.2mm, it should be added that the only trouble when using the connector with a PCB which is less than 0.8mm thick is that play may develop between the PCB and metal retainers. The connector can therefore be used if it is clamped or some other measure is taken to secure it.
The same applies when the 1.6mm type connector is used with a PCB which is less than 1.6mm thick.
8. Please take care of excessive force to flange. (Recommended torque tension: 0.25 N·m to 0.29 N·m)
Tightening too much may damage the threads or screw head. Please be careful.

Regarding general notes,
please refer to page 8.